

Wheel Finishing Solutions

AWP Vibratory Wheel Polishing Machine
WSB Alloy Wheel Blasting Machine



ActOn Surface Finishing Solutions for Wheel Finishing

ActOn Finishing specialises in innovative surface finishing solutions tailored for the automotive industry. Our state-of-the-art machines, the AWP Vibratory Wheel Polisher and the WSB Wheel Blasting Machine, deliver superior results, ensuring efficiency and consistency in wheel finishing.

ActOn Finishing is a leader in surface finishing solutions, proudly manufacturing in Britain. With over 60 years of experience, we specialise in providing innovative, high-quality machinery, media, and compounds tailored for the automotive industry. Our comprehensive range of finishing solutions ensures outstanding results, whether you need precision polishing, shot blasting, or customised finishing processes. By offering tailored media and compounds for the automotive industry, we help our clients achieve the best possible finishes while optimising efficiency and reducing costs. Our state-of-the-art machines, the AWP1 Vibratory Wheel Polisher and the WSB Wheel Blasting Machine, deliver superior results, ensuring consistency and excellence in automotive wheel finishing.



AWP Vibratory Wheel Polisher

The machine is suitable for achieving a highly polished finish on automotive wheels. The AWP machine has been designed to be simple to operate and produce excellent results.

At ActOn Finishing we have developed, in partnership with major manufacturers in the automotive industry, a high quality, repeatable finishing solution to achieve a highly polished finish in just a few hours. Our technical representatives can guide you to find the right media and compound to process your wheels and to achieve the mirror finish in the wheel finishing machine.

Key Benefits

- Both automotive wheels and motor bike wheels can be finished.
- Great for polishing worn automotive wheels and other components.
- Design includes system to clamp wheels with different sizes (up to 24" / 610 mm).
- Both forged and casted wheels can be processed in the AWP machine.
- Reliable and repeatable finish each time.
- Low maintenance.
- Cost and time saving.
- Durable machine due to design, good quality materials and workmanship knowledge.
- Proudly manufactured in Great Britain

Request a [quotation](#) today!

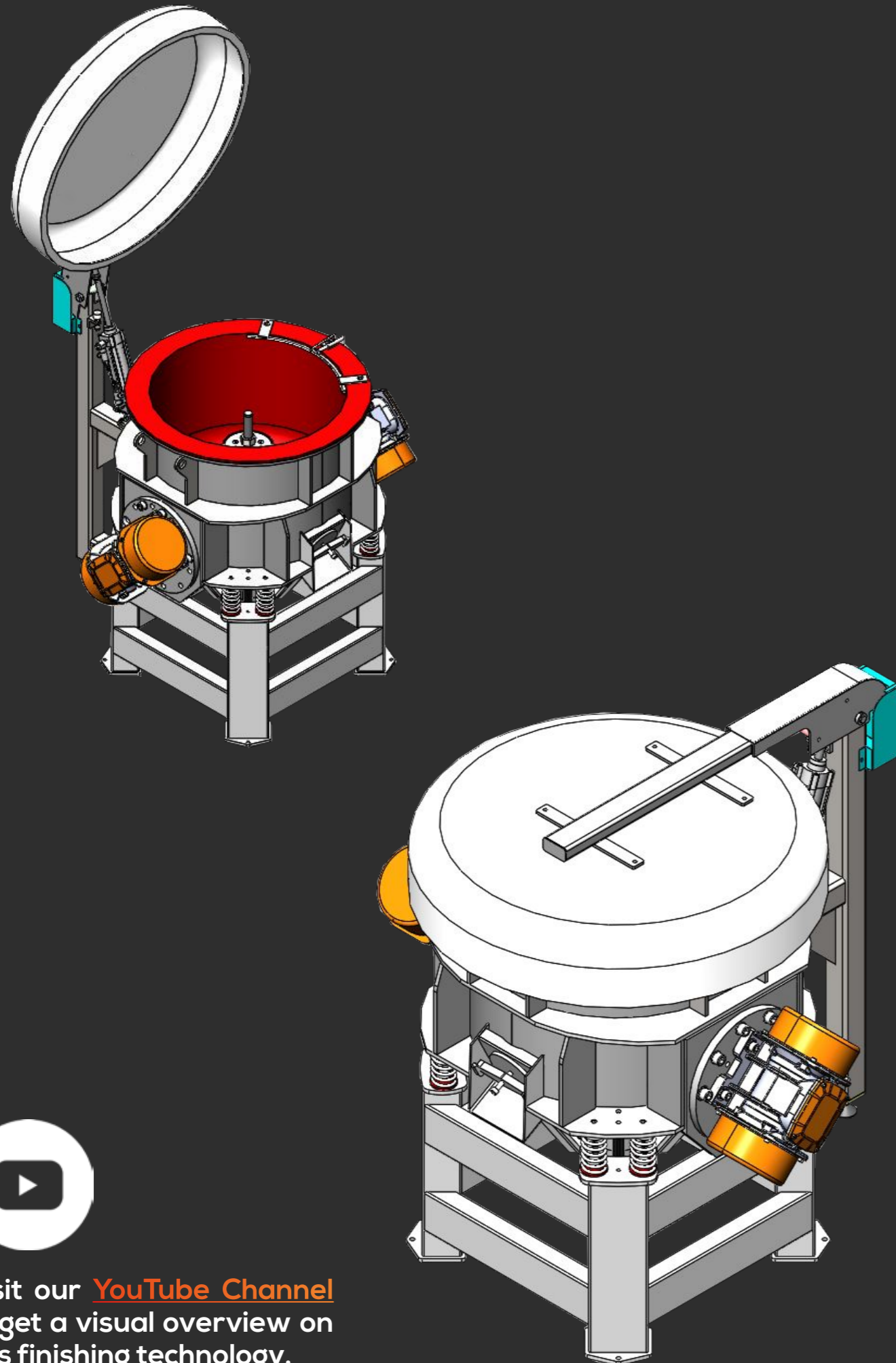

Key Features

- AWP-P model available with pneumatic unloading system.
- Wear resistant polyurethane lining.
- Stainless steel 90° dosing pump for dosing water and compound.
- Compact design.
- Drive system with sealed bearings for maintenance-free running.
- Standard control panel to control machine functions including isolator, on/off controls and timer.
- Speed control (optional).
- Pneumatic acoustic lid (optional).
- Polyurethane drain with 2mm holes.
- Stainless steel drain (optional).

Technical Specifications

Description	AWP-188	AWP-188P	AWP-240	AWP-240P
Capacity Litres / Cu. Ft.	188 / 6.6	188 / 6.6	240 / 8.5	240 / 8.5
Machine Dimensions (L x W x H) in mm/inch	1450 x 860 x 1220 /57 x 33.8 x 48	1450 x 860 x 1220 /57 x 33.8 x 48	1550 x 960 x 1250 /61 x 37.8 x 49.2	1550 x 960 x 1250 /61 x 37.8 x 49.2
Chamber Dimension after PU lining (ø x H) in mm/inch	720 x 500 / 28.3 x 19.7	720 x 500 / 28.3 x 19.7	780 x 530 / 30.7 x 20.8	780 x 530 / 30.7 x 20.8
PU Thickness in mm/inch	15 to 20 / 0.6 to 0.8	15 to 20 / 0.6 to 0.8	15 to 25 / 0.6 to 1	15 to 25 / 0.6 to 1
Motor Rating kW/rpm	2x 0.6 / 1500	2x 0.6 / 1500	2x 0.75 / 1500	2x 0.75 / 1500
Max Wheel Size in mm/inch	620 / 24.4	620 / 24.4	680 / 26.7	680 / 26.7
Approx. Weight in Kg.	450	463	575	590

Sizes indicated above are standard. Custom sizes can be manufactured to suit specific applications. Dimensions are subject to change due to design improvements.



Visit our [YouTube Channel](#) to get a visual overview on this finishing technology.

Process Application

To achieve a highly polished finish wheels can go through 3 processing steps:

Step 1: Cut down

Wheels go through the grinding process using the PWP media** and LQ16 which is a concentrated cleaner and polishing compound. Depending on the initial condition of the surface the process time can take between 2 to 6 hours*.

Step 2: Smoothing

After the surface has been cut down it needs to be smoothed and prepared for the polishing stage. This is achieved using PKW media** and LQ16 compound. The time needed to carry out this process can vary from 2 to 3 hours*.

Step 3: Polishing

The final stage includes polishing the wheels with PHD polishing media** and LQ9 compound. The process time can take between 1 to 3 hours*. This media is great for achieving a bright highly polished finish while LQ9 has been formulated for polishing both ferrous and non-ferrous metals.

* This is only a guideline and duration of finishing process may depend on the initial condition of the wheels.

** Size and shape of media will be selected to suit part geometry and avoid any lodgement.

Depending on the initial surface condition some wheels may only require the last 2 stages.

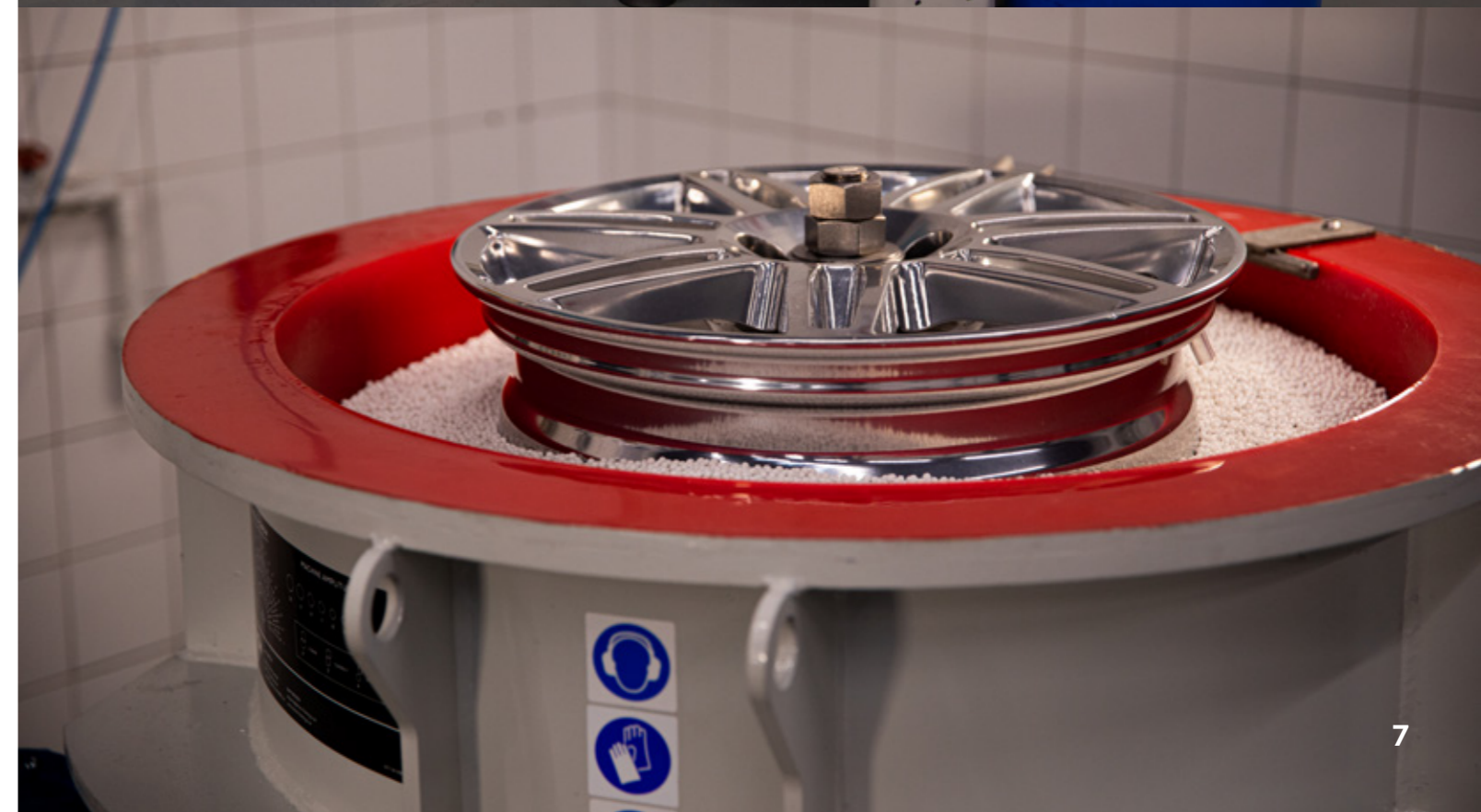

WSB Alloy Wheel Blasting Machine

The WSB blasting machine is suitable for shot blasting automotive alloy wheels, in a shorter period of time. This automated blasting cabinet has been designed to be simple to operate and produce excellent results.

The WSB blaster has been built to shot blasting alloy wheel using steel shots and grit. The result is a wheel rim with a surface roughness between 28µm-35µm.

Key Benefits & Features

- Creates a surface perfect for powder coat application.
- Wheels can be loaded in just 20 seconds.
- Average process time is 60 seconds for each side of the wheel.
- Average process time is 90 to 120 seconds for each side of the highly corroded wheel.
- Includes timer to control both the short and long processes.
- British built, high-quality product.
- Easy to maintain.
- Operator friendly.
- Repeatable high-quality results.
- Durable machine due to design, good quality materials and workmanship knowledge.



before



after

Technical Specifications

Machine Dimensions Including Dust Collector Unit & Control Panel (W x H x D) in mm/ inch	1240 x 1810 x 2200 / 48.8 x 71.2 x 86.6
Blast Chamber Size (W x H x D) in mm/ inch	800 x 765 x 850 / 31.5 x 30.1 x 33.4
Turbine RPM	2900
Media Requirement (in kg)	8 - 10
Power Supply	415 VAC, 50 Hz, 3 Ø
Power Consumption	15 kW
Dust Extractor Air Flow Rate	600 m ³ / hr
Residual Dust Content	≤ 1 mg/N m ³

Sizes indicated above are standard. Custom sizes can be manufactured to suit specific applications.

Dimensions are subject to change due to design improvements.

Request a [quotation](#) today!

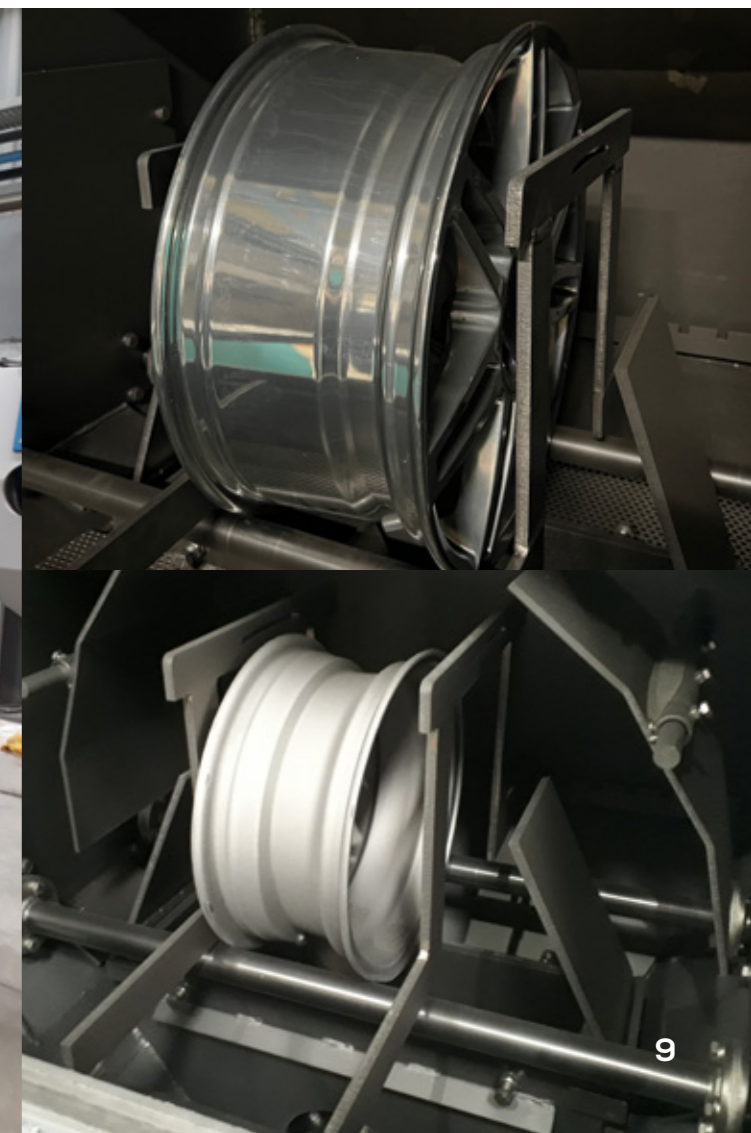

Finishing Consumables

ActOn Finishing offers a comprehensive range of finishing media and compounds, specifically developed for the automotive industry. Our selection includes ceramic, plastic, stainless steel, polishing, agro media, abrasive media, and specialised finishing compounds, ensuring that every wheel finishing requirement is met with precision and efficiency.

Key Benefits

- Specialised for automotive applications, ensuring optimal performance.
- High-quality consumables that provide repeatable, consistent results.
- We offer media and compounds tailored to specific wheel finishing needs.
- Eco-friendly formulations, reducing waste and environmental impact.
- Cost-effective solutions that enhance efficiency and longevity.

Finishing Applications

- Deburring:** smooth sharp edges and remove imperfections.
- Surface Preparation:** create an ideal surface for powder coating and painting.
- Polishing & Burnishing:** enhance the final finish, achieving a high-gloss, mirror-like surface.
- Degreasing & Cleaning:** effectively remove oils, dirt, and contaminants from alloy wheels.
- Rust & Oxide Removal:** ensure restoration and maintenance of corroded wheels.

Request a **FREE TRIAL** today!



What Our Customers Say

"Recently purchased a VB20S for use in our manufacturing for motorsport division. Good value, great vibratory bowl machine and attitude. professional sales, engineering and support pre and post installation, very much recommend."

Edward Beeston, Lohen

"ActOn were quick to develop a solution for the shell cleaning system. The disc finishing machine has improved our throughput significantly and we are pleased with the quality of machine that they have manufactured and installed. We look forward to working with ActOn on future collaborative projects."

Henry Illsley (Shell Process Engineer), Rolls Royce Bristol

Quality You Can See

We pride ourselves on our excellence, and over the years we have successfully demonstrated an ongoing compliance with ISO quality and environmental standards. We're also an approved supplier for many of our industries, including medical and aerospace.

For ISO, we currently hold:



we redefine

ActOn Finishing Ltd.

213 Torrington Avenue

Tile Hill, Coventry

CV4 9HN

United Kingdom.

+44 (0) 24 7646 6914

enquiries@acton-finishing.co.uk

www.acton-finishing.co.uk

ACTM-36-WFB
Issue 1